

D.O.O.F. Data Ownership Orchestration Framework

An Open Source Framework for decentralized consent management

Georgiana Bud

georgiana.bud@ecosteer.com

info@ecosteer.com

This project has received funding from the European Union's Horizon 2020 research and innovation program through the NGI TRUSTCHAIN program under cascade funding agreement No. [101093274](#).

Ecoteer technologies: Consent Management Framework

DATA OWNERSHIP ORCHESTRATION FRAMEWORK

- Technology: orchestration framework for decentralized consent management
- Functionalities: standardizes the development and deployment of applications that utilize PETs and adds data ownership functionalities, streamlining the process for developers and businesses alike
- Open-source

Ecosteer technologies: Privacy Enhancing Encryption Schemes

DATA VISIBILITY CONTROL OVERLAY

Applicable on: **DATA STREAMS**

multicast end-to-end encryption scheme

- Functionalities: data owners unilaterally grant and revoke visibility over data streams generated by connected devices to selected data recipients
- Patent: 'Multicast Encryption Scheme for Data Ownership Platform' (Patents granted in US, EU, CAN, Japan, Singapore, etc.)

RECORD LEVEL ENCRYPTION

Applicable on: **DATA SETS**

encryption scheme for data records

- Functionalities: data owners unilaterally grant visibility over data records maintained by service providers to selected data recipients
- Patent pending

EU Data Strategy

GDPR

**ENFORCED IN
MAY 2018**

Consent must be **granted** separately for each specific **purpose of use**.

Revoking consent must be as **easy** as granting it.

DATA GOVERNANCE ACT

**ENFORCED IN
SEPTEMBER 2023**

Create a framework to foster a new business model:

data intermediation services.

Provides a trusted and secure environment for companies and individuals to share data

DATA ACT

**ENFORCED FROM
SEPTEMBER 2025**

Users of **connected products** and related applications must be enabled to **share their data** with third parties of their choice

* <https://digital-strategy.ec.europa.eu/en/policies/data-intermediary-services>

** <https://gdpr.eu/gdpr-consent-requirements/>

Centralized approach: data intermediary costs and legal liabilities

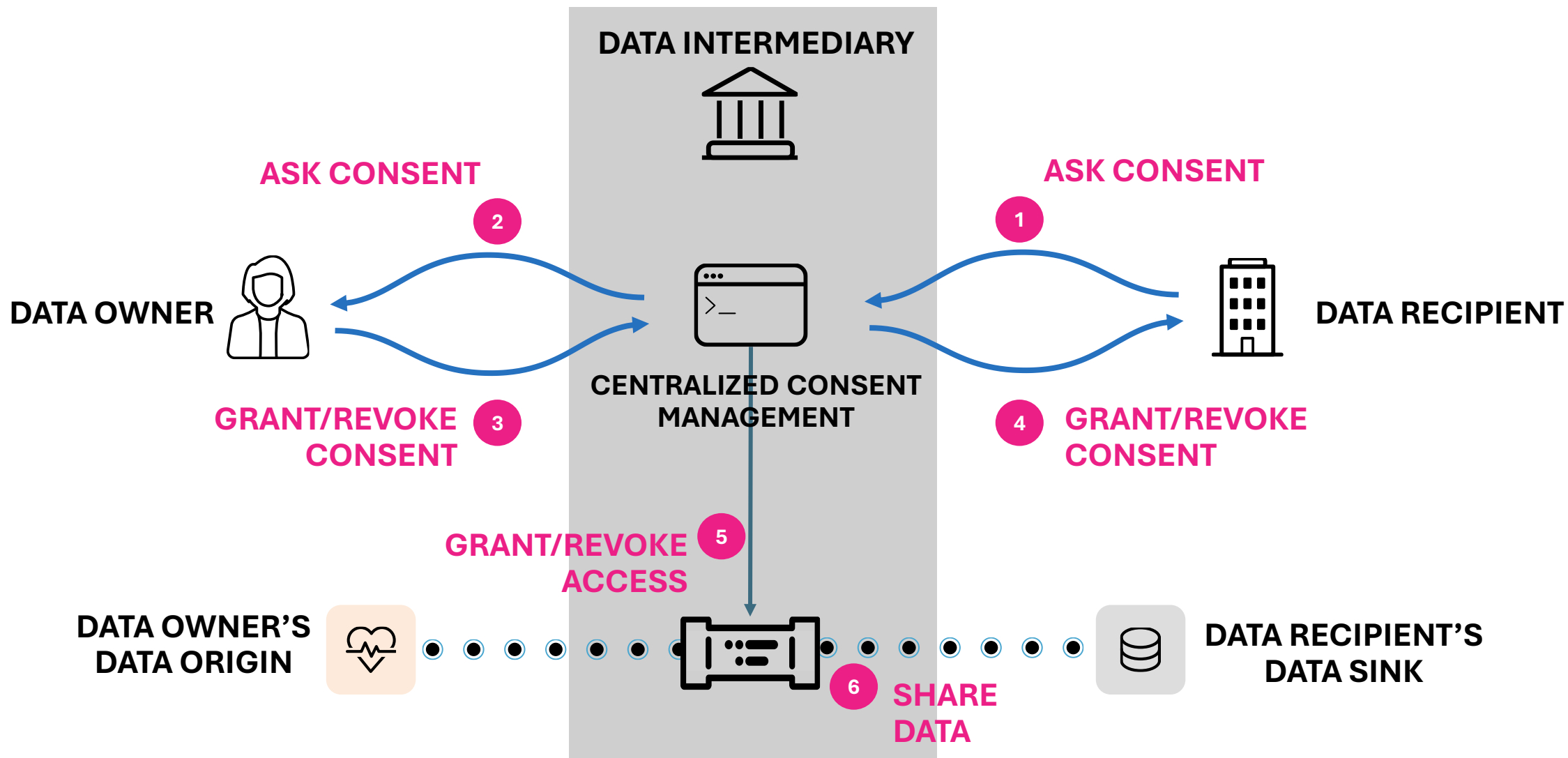

DOOF: the PILLARS

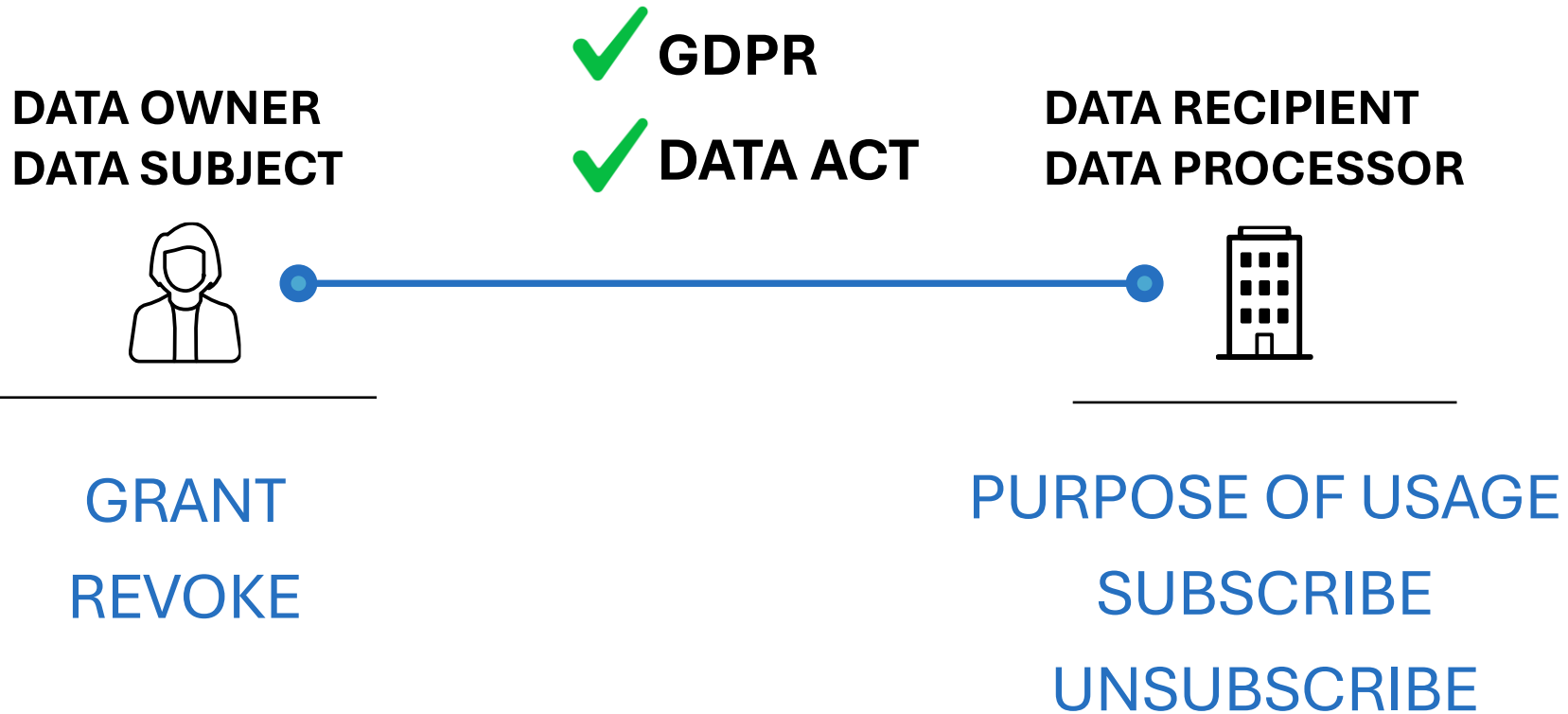

DOOF Architecture

Data Ownership Orchestration Framework

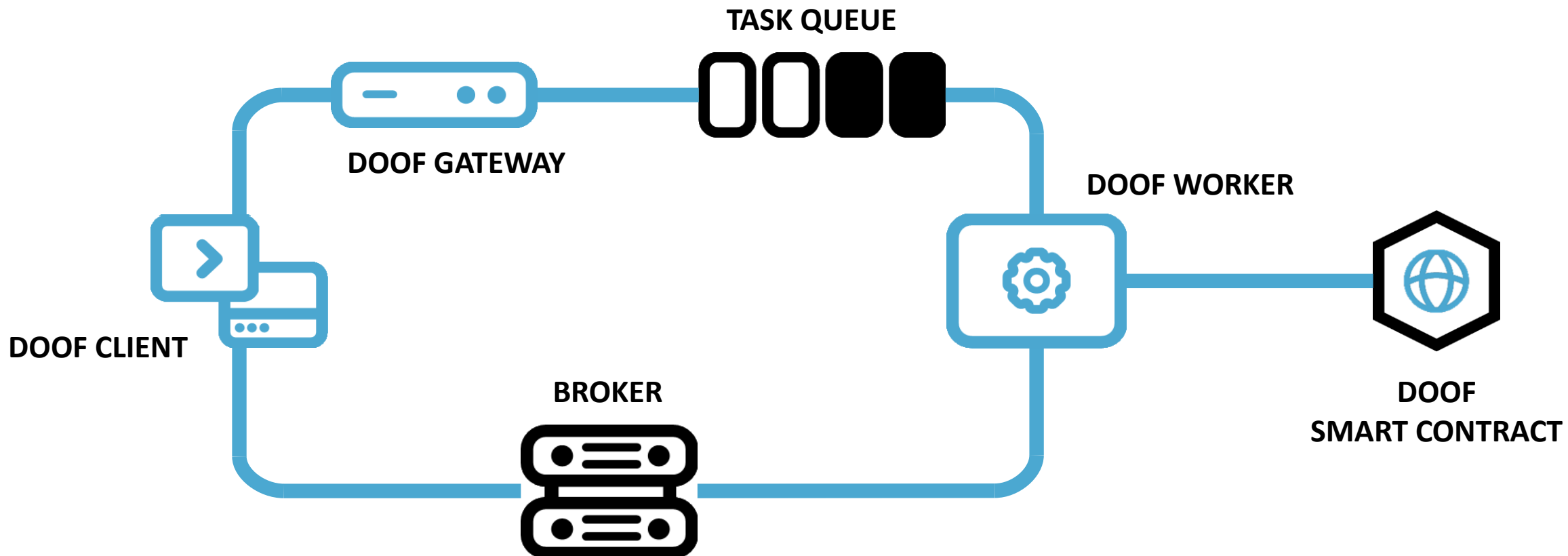

DOOF Smart Contract

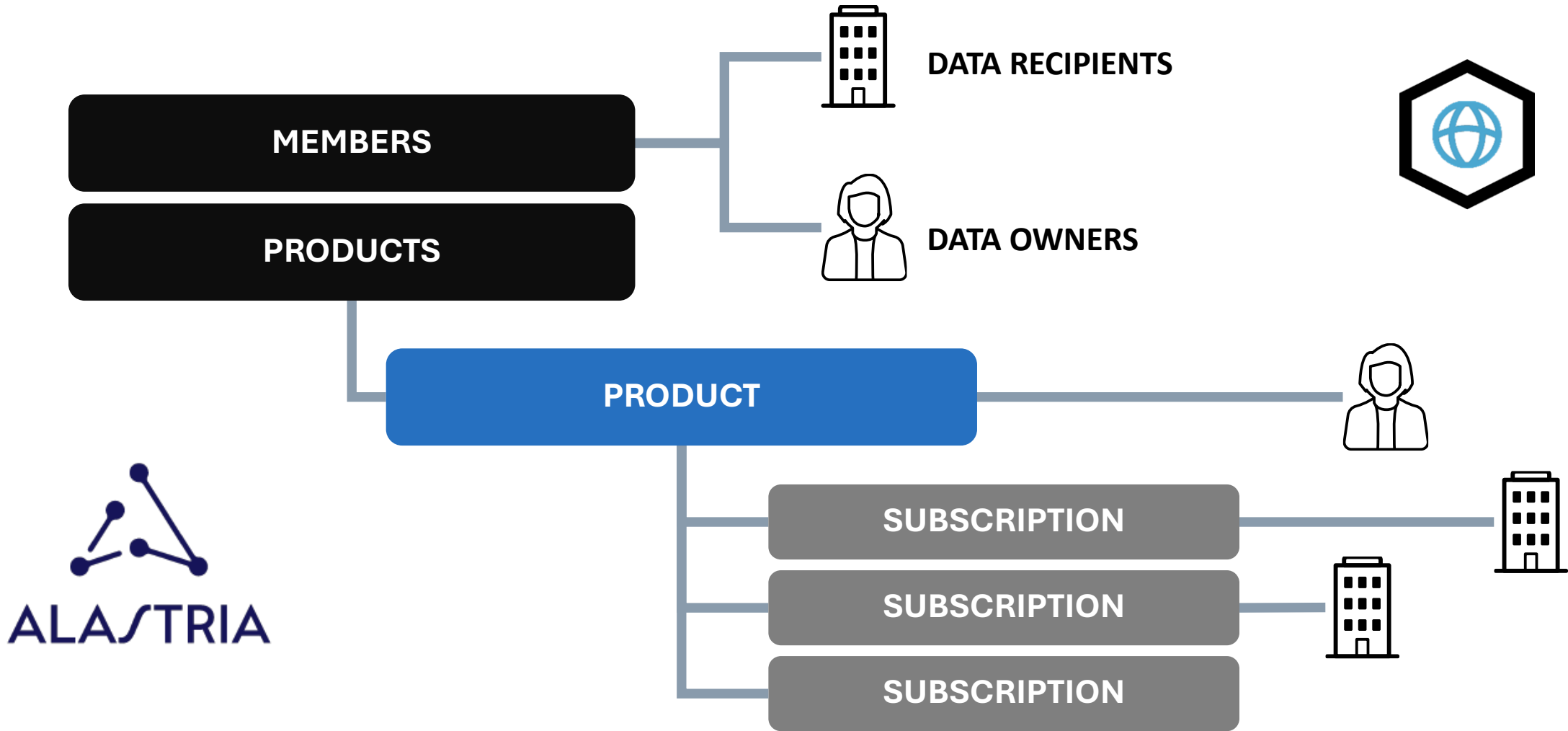

DOOF Client

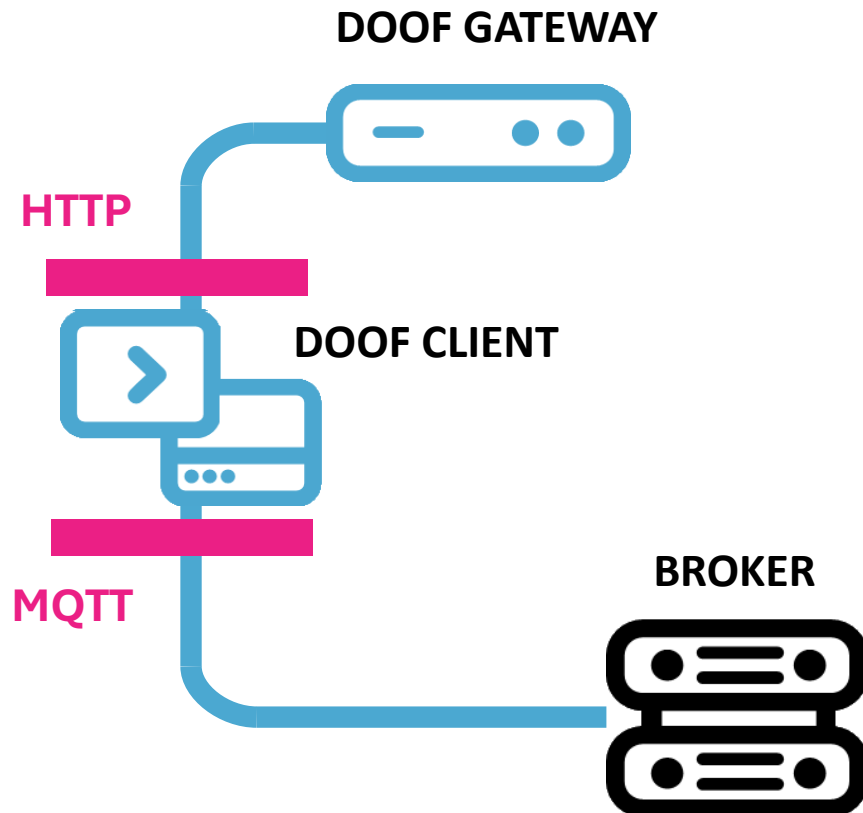

```
{  
  "session": "8abbc354-7258-11e9-a923-1681be663d3e",  
  "task": 1,  
  "event": "dop_subscription_grant",  
  "params": {  
    "auth_token": "25db23fd0515445e93fd6388762cf556",  
    "subscription_id": "022C84FF-3DA3-4BE0-9C1C-0A4E9ED1BE5A"  
  }  
}
```

DOOF Gateway

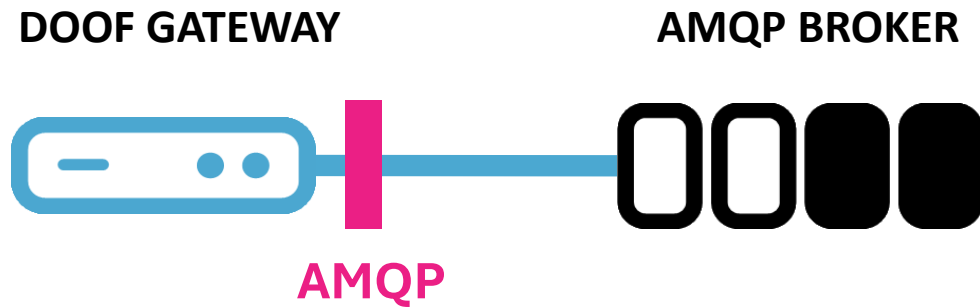

Standard HTTP Server deployment:

- Security via HTTPS
- Validates requests and forwards them to work queue (AMQP) for scalability
- Authentication (outside the scope of the DOOF Gateway)

DOOF Worker

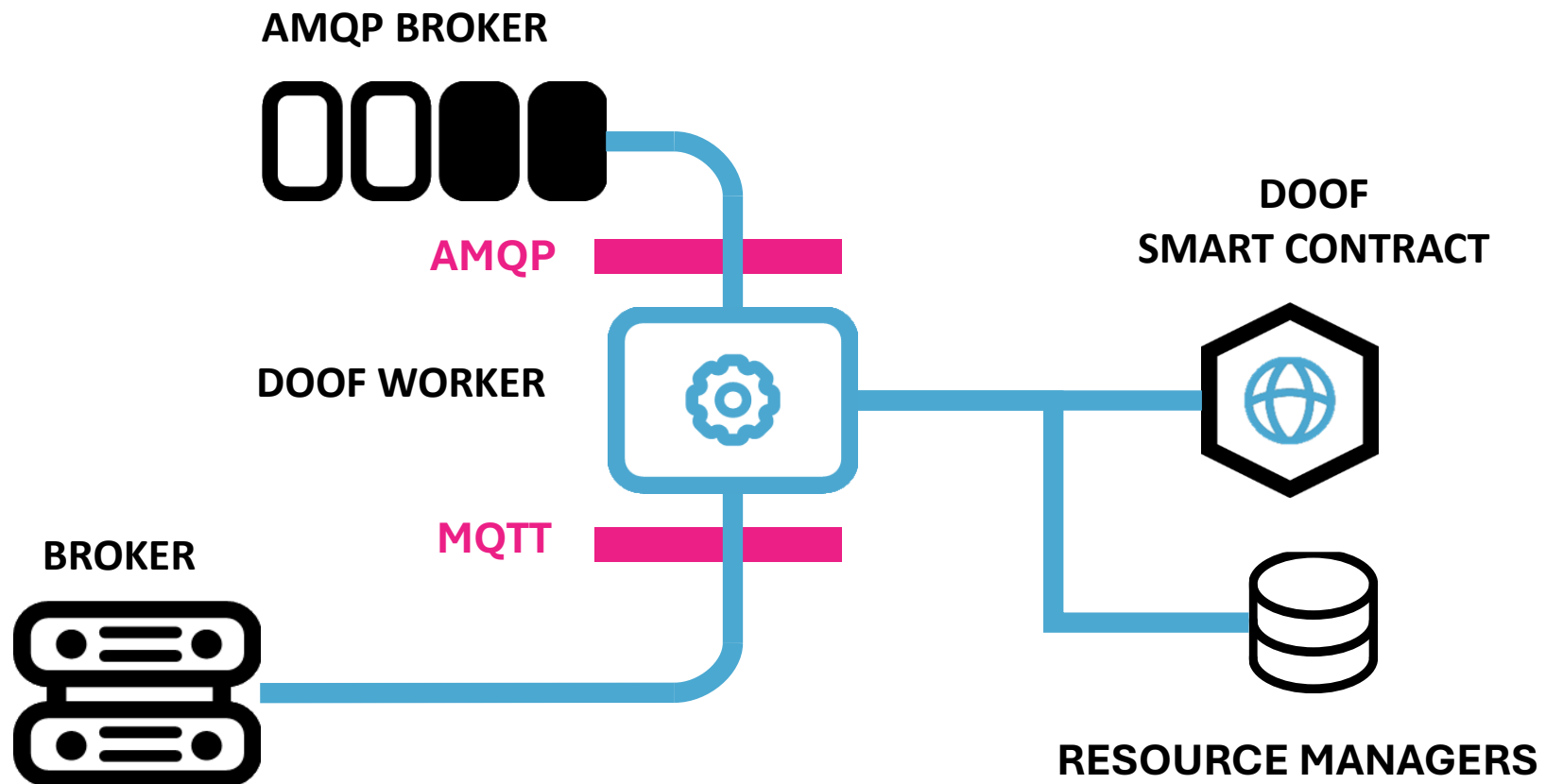

DOOF Worker Execution Framework

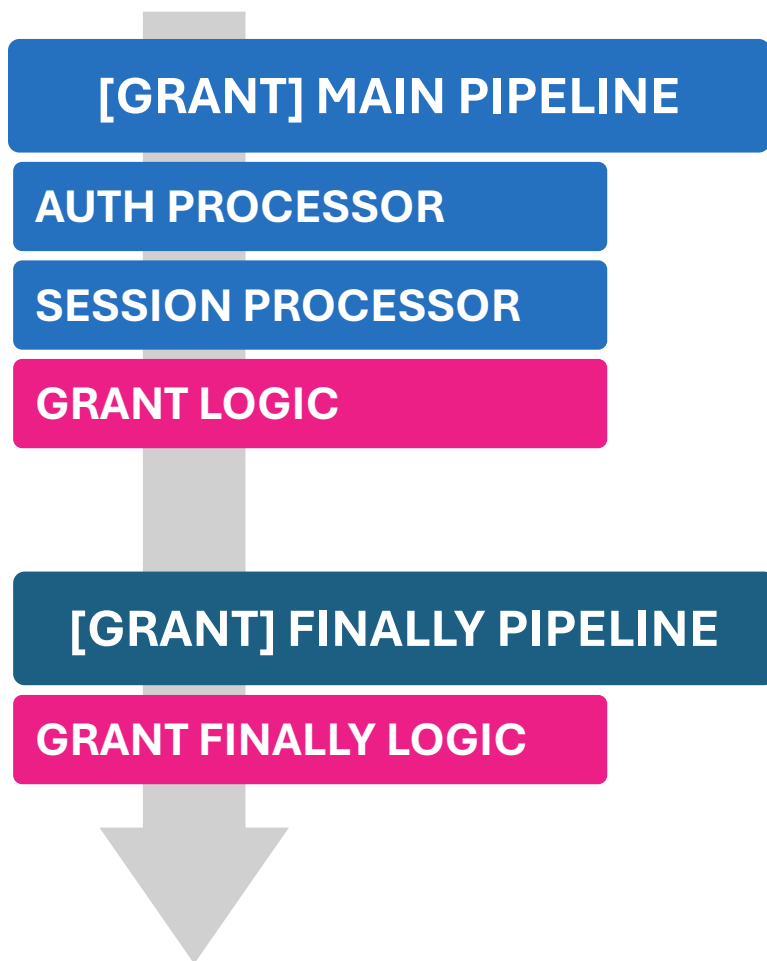

```
"dop_subscription_grant" :  
  {  
    "main": [  
      "$AUTH_MACRO",  
      "$UPDATE_SESSION_MACRO",  
      "$MLE_LOOKUP",  
      {  
        "path": "/home/user/doof/provider/processor/dop_subscription_grant.py",  
        "class": "DopSubscriptionGrantProcessor",  
        "configuration": ""  
      }  
    ],  
    "finally": ["$FINALLY_MLE_ENCRYPT"]  
  }
```

Worker execution phases

```
{  
...  
  "event":  
  "dop_subscription_grant",  
  "params": {...}  
}
```



INPUT VALIDATION

- ✓ JSON
- ✓ «event» is present

Worker execution phases



Worker execution phases

```
{  
...  
  "event":  
  "dop_subscription_grant",  
  "params": {...}  
}
```



INPUT VALIDATION

PIPELINE SELECTION

PIPELINE EXECUTION



JSON



«event» is present

Worker execution phases

```
{  
...  
  "event":  
  "dop_subscription_grant",  
  "params": {...}  
}
```



Worker execution phases

```
{  
...  
  "event":  
  "dop_subscription_grant",  
  "params": {...}  
}
```



INPUT VALIDATION

PIPELINE SELECTION



PIPELINE EXECUTION



FINALLY PIPELINE



NOTIFICATION

```
{  
"task": 1,  
  "event":  
  "dop_subscription_grant",  
  "params": {"err": 0 ,  
  "phase" :1 }  
}
```



JSON



«event» is present

DOOF Worker Main Pipeline Design

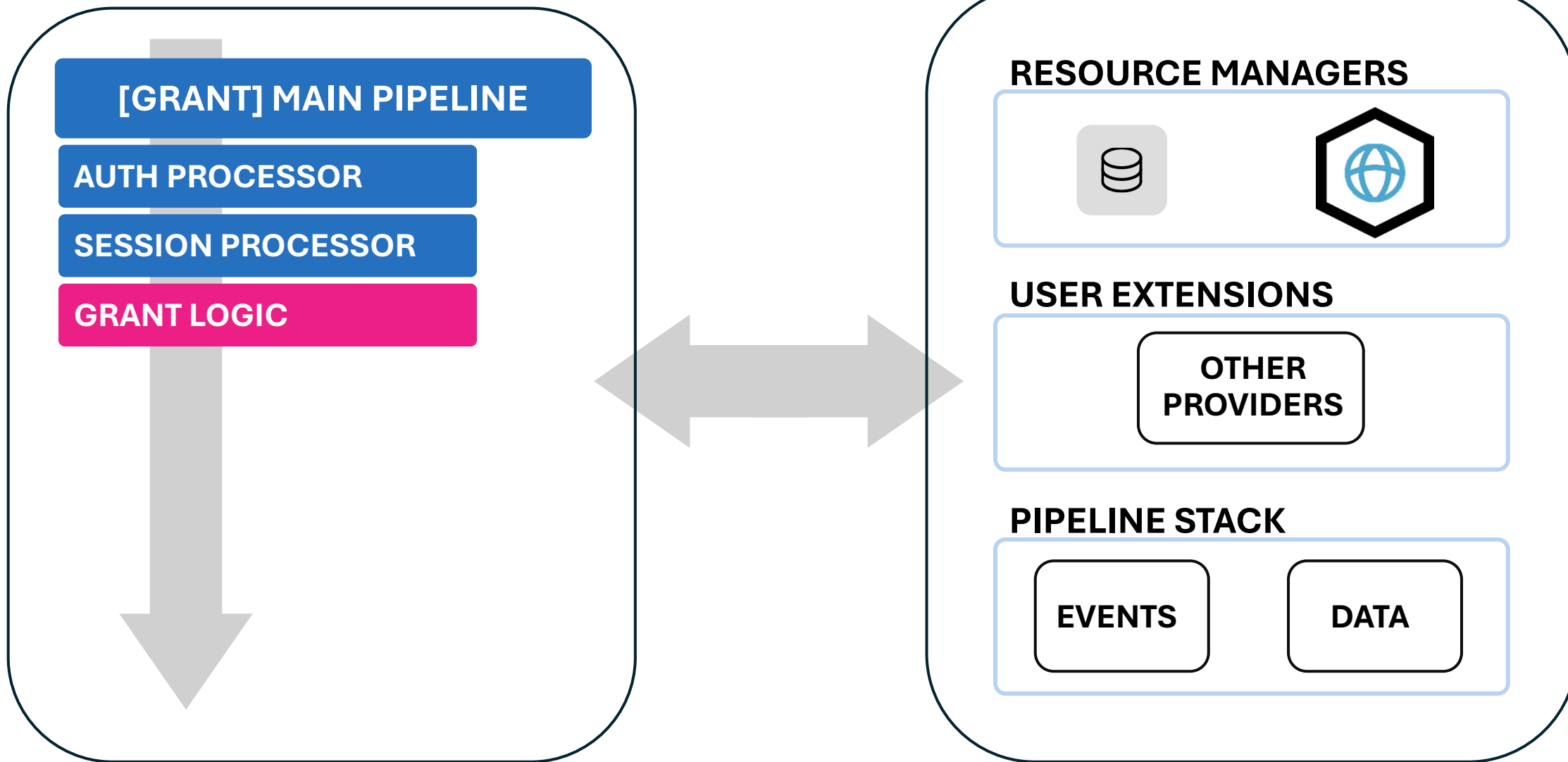

DOOF Worker Finally Pipeline Design

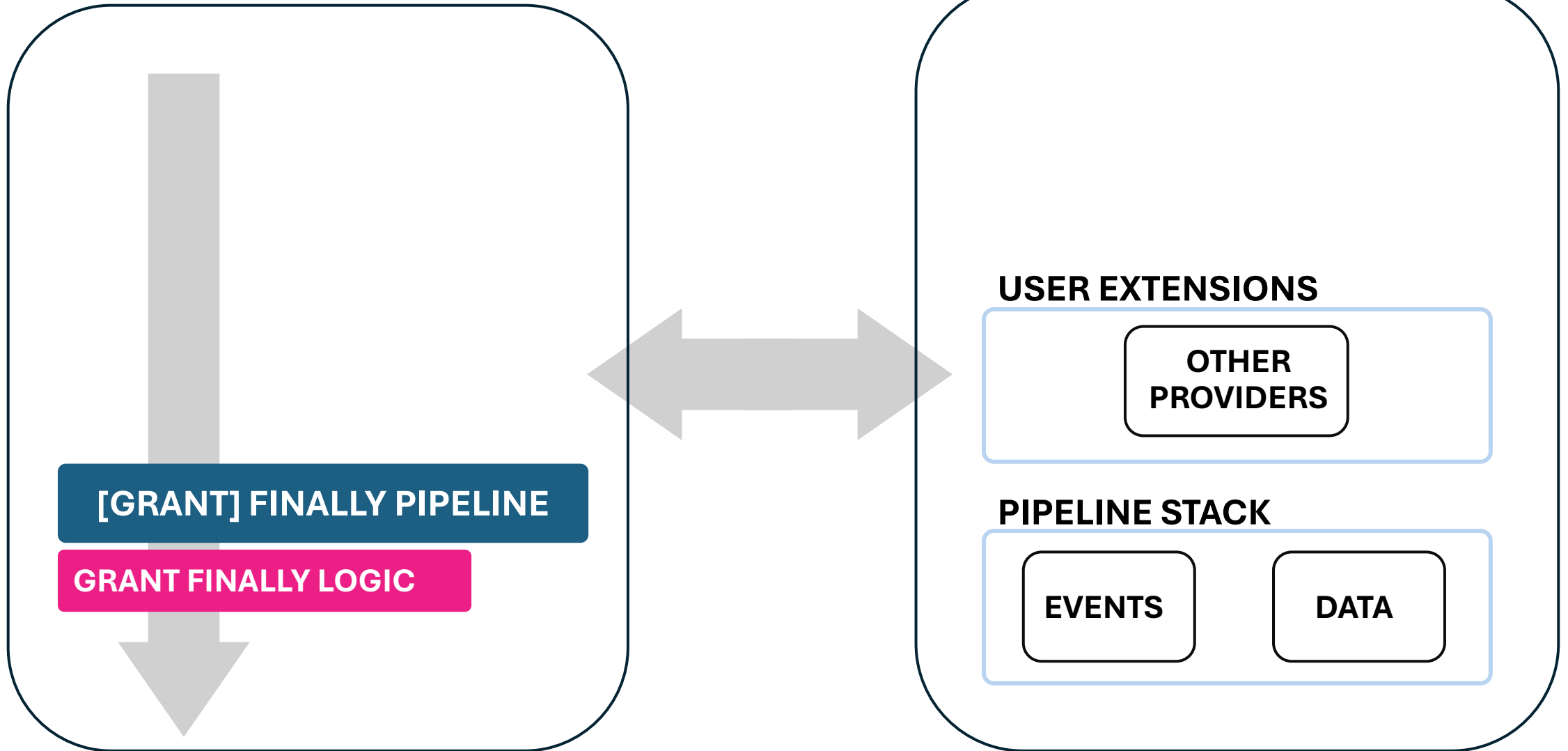

DOOF Worker Notification

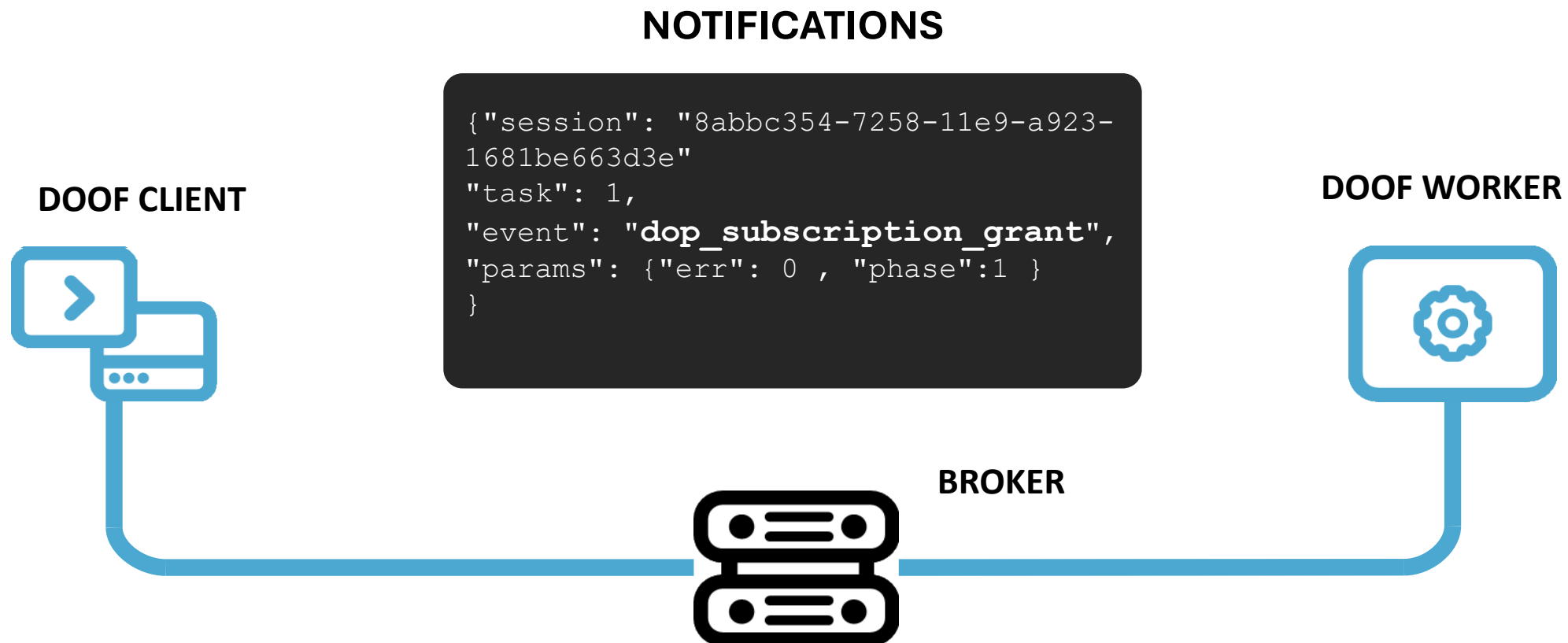

Air Quality Data Exchange

The screenshot shows a web interface titled "Data Exchange" for user "Gabi San" (gabisan@ecosteer.com). The left sidebar contains navigation options: Billboard, Assets (highlighted), Notifications, Messages, Useful Info, Settings, and Sign Out. The main content area shows "Qubee 000138" with a date of "17 mag 2024". It features two status buttons: "3 Approved" and "0 Not Approved". Below this, there are three data request entries, each with a green checkmark, a requester name, a request date, and a "See my own data" or "Purpose of usage" link.

The screenshot shows a "Data Owner's Subscription App" interface for user "georgib@ecosteer.com". It displays a "TVOC VALUE" of 252 in a circular gauge. To the right is a line graph showing TVOC levels over time from 16:24:23 to 16:25:12. The y-axis ranges from 252.0 to 257.0. The graph shows a peak around 16:24:40 and a sharp decline thereafter.



Integration with Privacy Enhancing Technologies (PETs)

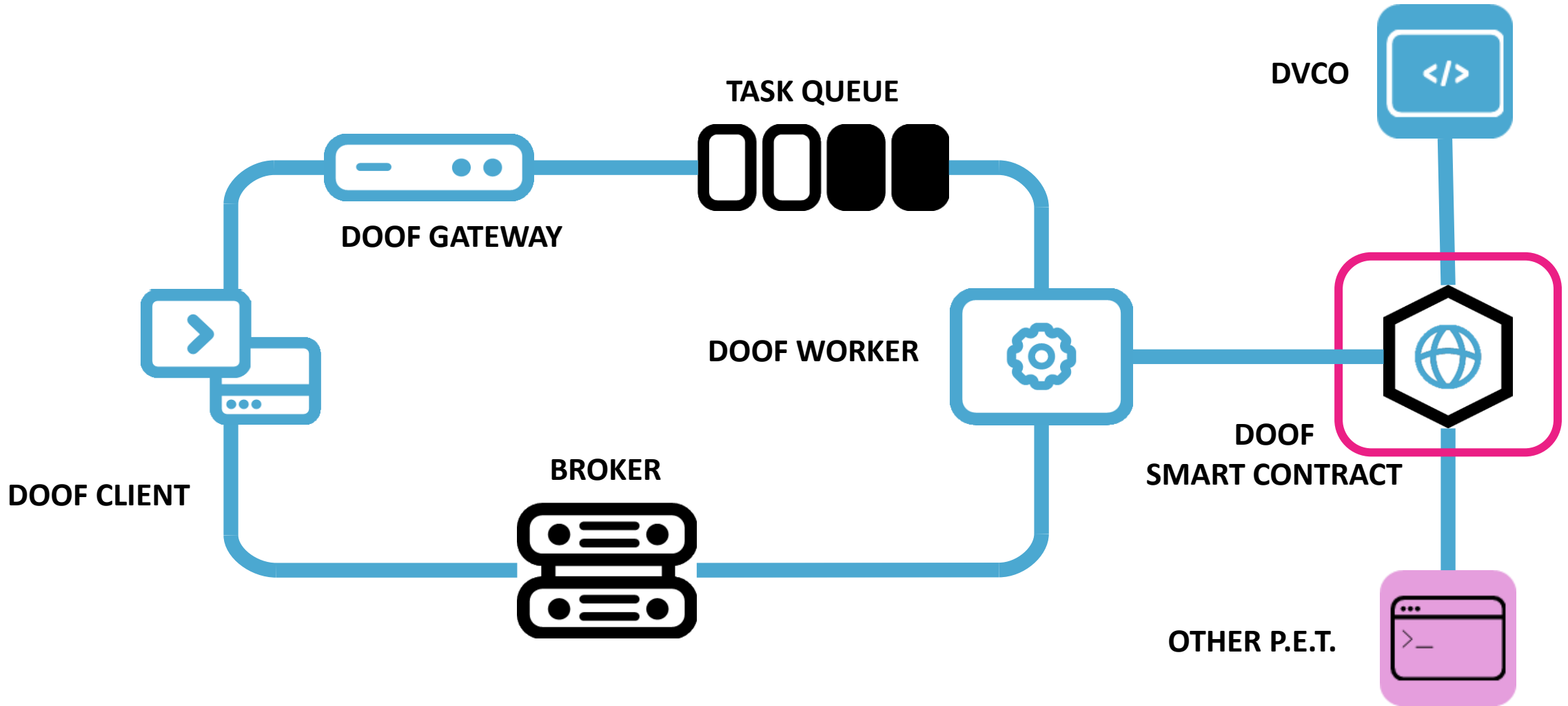

Decentralization and Neutral Data Intermediaries

Decentralizes consent, enabling direct data owner-recipient connections and neutral intermediaries

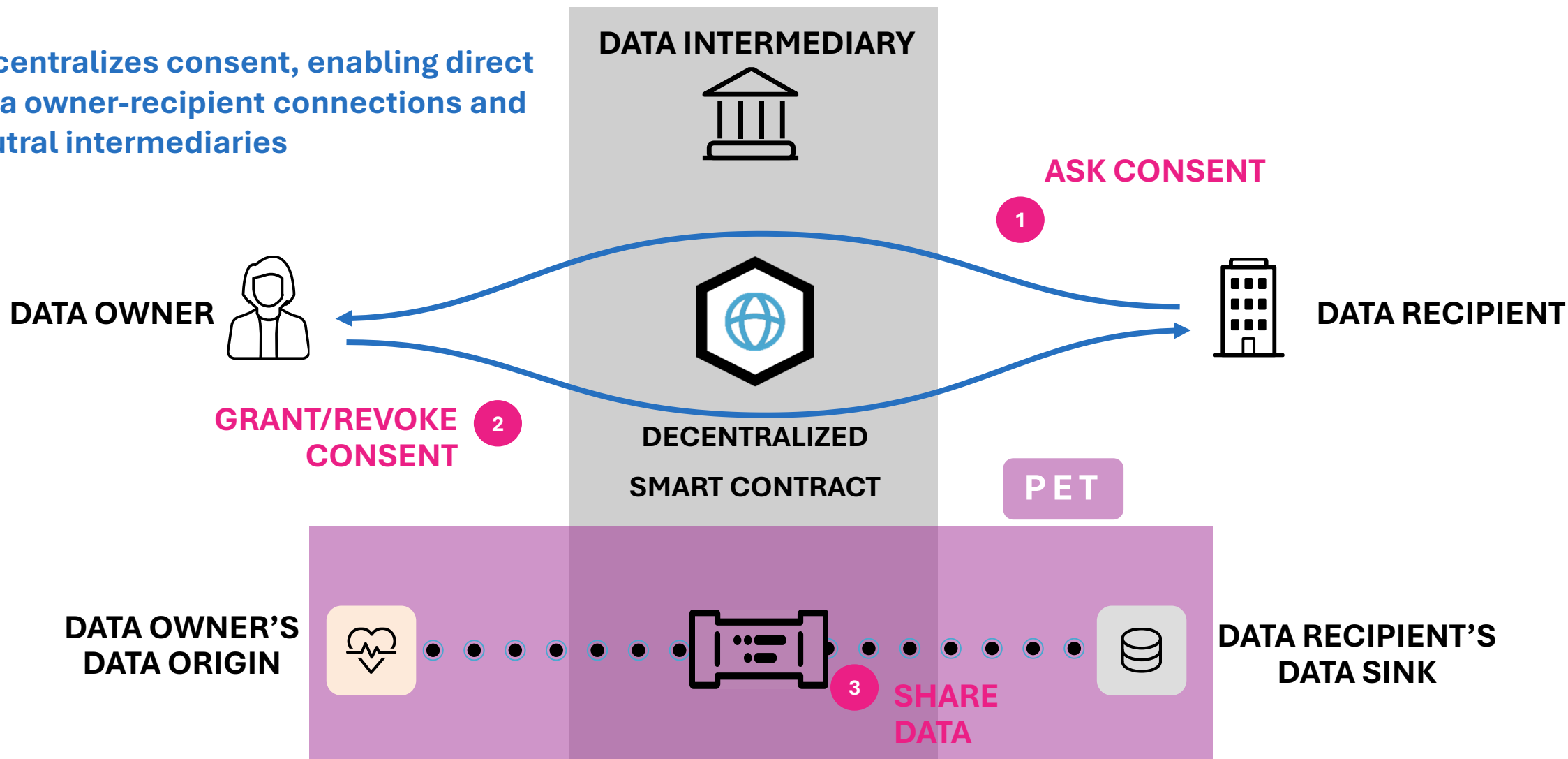

Horizontal Solution

Flexible, cross-sector architecture supports various data and access types



Energy



Mobility



Healthcare



Banking

Scalability and Availability

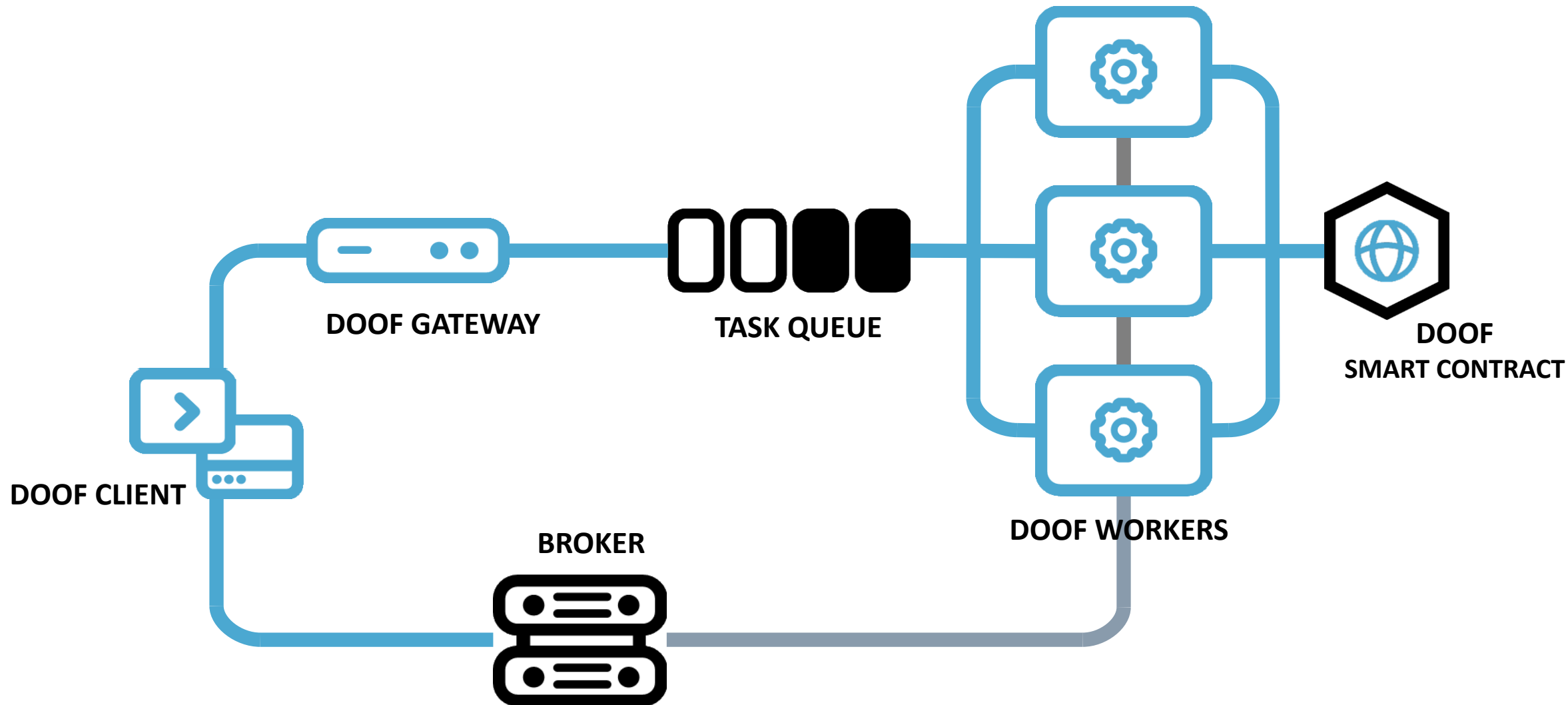

DOOF

DOOF.

Decentralized Consent
Management

Technical
Implementation of
GDPR Principles

Scalable Extendible
Pipeline

Thank you!

Georgiana Bud

georgiana.bud@ecosteer.com

info@ecosteer.com